

DIGITAL ROCKWELL HARDNESS TESTER

FR-X Series

FR-X1, FR-X2, FR-X3, FR-X1L, FR-X2L, FR-X3L, FR-XA



FR-X Series

FR-X1, FR-X2, FR-X3 FR-X1L, FR-X2L, FR-X3L

Obtained the supreme precision and overwhelming reliability by the adoption of entirely new designing and precision manufacturing with no compromise!
By the adoption of stealth type double information panel, improved the remarkable visibility and operation!



Features

■ EMPHASIZED HIGH PRECISION

Reviewed the popular FR-e series and achieved the supreme precision.

■ STRENGTHENED BODY

Achieved the remarkable improvement of hardness measurement by the adoption of newly designed strong body.

■ STABLE LOADING AXIS MECHANISM

Adopted highly sensitive load shaft to prevent the side shift by the introduction of ball guide at the top and bottom. The stable measurement of hardness has become possible for the cylindrical and spherical surface.

■ STANDARD COMPENSATION FUNCTION

Low, middle, high compensation of multiple points to meet the each standard. Obtain the test result which is comply with the different standard for all hardness range.

■ SHAPE COMPENSATION FUNCTION

Obtain the test result which is comply with the standard by entering the diameter of spherical surface & cylindrical specimen.

■ DISPLAY OF MAX.DEPTH OF INDENTER

Display the max.depth of indenter together with test result. Be able to evaluate the elastic amount of different sample in hardness value.

■ STEALTH TYPE DOUBLE INFORMATION PANEL

Display the various information of OK/NO judgement and conversion and at the same time, display the measurement results.(Load and release of the test road, and hardness indication are automatic)

■ FUNCTION OF DATA JUDGEMENT

Display the judgement of measurement data (HI, OK, LO), if you set the maximum value and minimum one and the mean value, if you set measurement point on the sub-information panel.

■ LED LIGHT

Obtained the supreme visibility of specimen in the dark environment and achieved the minute positioning.

FR-X SERIES STANDARD SPECIFICATION (EXCLUDING FR-XA)

MINOR LOAD POSITION SETTING	Automatic setting (Electronic sound monitoring)
LOAD CONTROL	Automatic (Application-holding-release)
START OPERATION	Automatic start / Manual start
LOAD REQUIRED TIME	1-8 sec (Constant speed)
DWELL TIME	1- 999 sec (Key entry in unit of 1 sec / Factory setting : 5 sec)
PLASTIC MEASUREMENT MODE	Standard function (Time up to hardness value display after release of test load : 1 to 999 sec)
HARDNESS CONVERSION	Capable in compliance with SAE (J -417b) & ASTM (E-140).
STANDARD CORRECTION	Low, middle, high (3levels) compensation of multiple points to meet the each standard.
SHAPE CORRECTION	Compensate and display the hardness value of cylindrical (CYL) and spherical (SPH) specimen. (Enter the radius of cylindrical specimen. Enter the diameter of spherical specimen.)
MAX.DEPTH OF INDENTER MEASURING FUNCTION	Display the value of max.depth of indenter.
AVERAGE VALUE CALCULATION FUNCTION	Calculate the average value. (Enter the number of measuring point)
OK / NG CRITERIA	Upper and lower limit setting, and HI / OK / LO display (HR 0 to 130, min. 0.1 hardness setting)
DATA TRANSFER FUNCTION	USB (B2.0) Connector (Option)
OUTPUT SIGNAL	RS232C (Baud rate : 9,600 bps)
RS-232C OUTPUT & PRINTOUT MODE	①Measurement data only ②Measurement data and evaluation results (Max. value, min. value & HI / OK / LO) ③Measurement data and conversion data ④Measurement data, conversion data and evaluation results (Max. value, min. value & HI / OK / LO) ⑤Measurement data and average value ⑥Max.depth of indenter and measurement data
COMPLIANT STANDARD	Conform to ASTM E18 A1, JIS B-7726
POWER SUPPLY	Single phase AC 100V, 50 / 60Hz in Japan and AC 100 ~ 240V, 50 / 60Hz available for Export Model. (Select when ordering)

STANDARD ACCESSORIES

CODE No.	ITEM	FR-X1	FR-X1L	FR-X2	FR-X2L	FR-X3	FR-X3L
R - 0 1 2	HARDNESS STANDARD BLOCK	HRC	1	—	—	1	—
R - 0 1 4		HRBS or HRBW	1	—	—	1	—
R - 0 1 5		HR30N	—	—	1	—	1
R - 0 1 6		HR30TS or HR30TW	—	—	1	—	1
R - 0 0 2	DIAMOND INDENTER	For ROCKWELL Type	1	—	—	—	—
R - 0 0 3		For SUPERFICIAL & TWIN Type	—	—	1	—	1
R - 0 0 4	STEEL BALL INDENTER OR CARBIDE BALL INDENTER (ϕ 1/16" / ϕ 1.588mm) ※SELECT EITHER ONE WHEN ORDERING		1	—	1	—	1
R - 0 0 8	SPARE STEEL BALL OR SPARE CARBIDE BALL (ϕ 1/16" / ϕ 1.588mm) ※SELECT EITHER ONE WHEN ORDERING	WHEN STEEL BALL INDENTER IS SELECTED	10	—	10	—	10
		WHEN CARBIDE BALL INDENTER IS SELECTED	2	—	2	—	2
R - 0 2 1	ANVIL	FLAT (ϕ 60mm)	1	—	1	—	1
R - 0 2 2		V-SHAPE (LARGE)	1	—	1	—	1
R - 0 4 2	POWER CABLE (3P-2.5mm)	—	—	1	—	—	1
R - 0 4 3	LEVEL ADJUSTING LEG	—	—	4	—	—	4
R - 0 4 4	MACHINE COVER	—	—	1	—	—	1
	INSTRUCTION AND MAINTENANCE MANUAL	—	—	1	—	—	1
R - 0 4 5	ACCESSORY BOX	—	—	1	—	—	1

FR-X Series

FR-X1

FR-X2

FR-X3



SPECIFICATIONS

	FR-X1	FR-X2	FR-X3
MINOR LOAD	N: 98.07 kgf: 10	N: 29.42 kgf: 3	N: 29.42 & 98.07 kgf: 3 & 10
TEST LOAD	N: 588.4 980.7 1471 kgf: 60 100 150	N: 147.1 294.2 441.3 kgf: 15 30 45	N: 147.1 294.2 441.3 kgf: 15 30 45 N: 588.4 980.7 1471 kgf: 60 100 150
MAX.SPECIMEN HEIGHT (WITHOUT LEAD SCREW COVER)	255mm		221mm
MAX.SPECIMEN HEIGHT (WITH LEAD SCREW COVER ATTACHED)	135mm		101mm
MAX.SPECIMEN DEPTH	165mm		
DIMENSIONS	W196×D487×H820mm		
WEIGHT	82kg	80kg	83kg

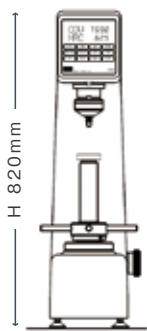

W 196mm

□ Front view

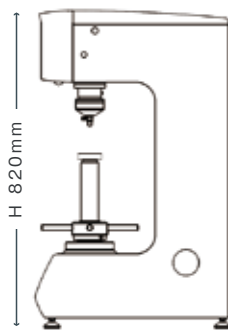

D 487mm

□ Right view

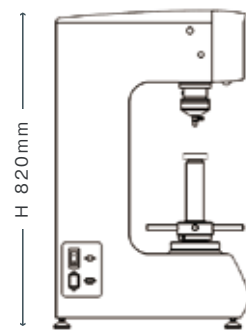

D 487mm

□ Left view



FR-X1L

FR-X2L

FR-X3L



SPECIFICATIONS

	FR-X1L	FR-X2L	FR-X3L
MINOR LOAD	N: 98.07 kgf: 10	N: 29.42 kgf: 3	N: 29.42 & 98.07 kgf: 3 & 10
TEST LOAD	N: 588.4 980.7 1471 kgf: 60 100 150	N: 147.1 294.2 441.3 kgf: 15 30 45	N: 147.1 294.2 441.3 kgf: 15 30 45 N: 588.4 980.7 1471 kgf: 60 100 150
MAX.SPECIMEN HEIGHT (WITHOUT LEAD SCREW COVER)	435mm		401mm
MAX.SPECIMEN HEIGHT (WITH LEAD SCREW COVER ATTACHED)	325mm		291mm
MAX.SPECIMEN DEPTH	165mm		
DIMENSIONS	W196×D487×H965mm		
WEIGHT	87kg	85kg	88kg



□ Front view

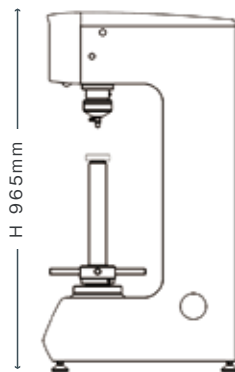

□ Right view

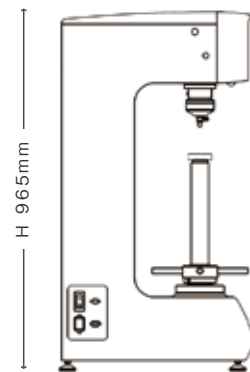

□ Left view

FR-X Series

ANALOG ROCKWELL TYPE HARDNESS TESTER FR-XA

High Reliability with Simple Structure and Strong Body.
Economical Model made much of Utility.



(HARDNESS DISPLAY)

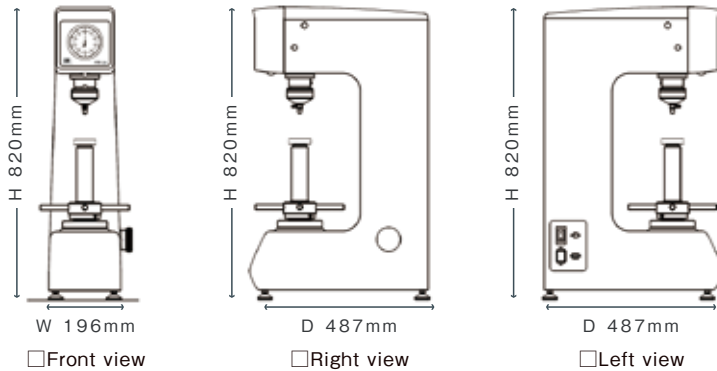

FR-XA SPECIFICATIONS

CONSTRUCTION		Dial Gauge / Motorized
LOAD	MINOR LOAD	N: 98.07 kgf: 10
	TEST LOAD	N: 588.4 980.7 1471 kgf: 60 100 150
		Dial Changing Type
MINOR LOAD POSITION SETTING		Manual setting on Green Range of Dial Gauge
LOAD CONTROL		Automatic (Application – Holding – Release)
START OPERATION		Manual start
LOAD REQUIRED TIME		1-8 sec (Constant speed)
DWELL TIME		Approx.2 sec (fixed)
SCALE DISPLAY		Read on Hardness Display For A,C,D Scale : White figures For Other Scale : Red figures
MAX.SPECIMEN HEIGHT		255mm (With lead screw cover attached : 135mm)
MAX.SPECIMEN DEPTH		165mm
DIMENSIONS		W196×D487×H820mm
WEIGHT		82kg
COMPLIANT STANDARD		Conform to ASTM E18 A1 • JIS B-7726
POWER SUPPLY		AC100/115/220V (Select either one when ordering), 50/60Hz

FR-XA STANDARD ACCESSORIES

CODE No.	ITEM	Q'TY
R-012	HARDNESS STANDARD BLOCK	HRC 1
R-014		HRBS or HRBW 1
R-002	DIAMOND INDENTER	1
R-004	STEEL BALL INDENTER OR CARBIDE BALL INDENTER (φ 1/16" / φ 1.588mm) ※SELECT EITHER ONE WHEN ORDERING	1
R-008	SPARE STEEL BALL OR SPARE CARBIDE BALL (φ 1/16" / φ 1.588mm) ※SELECT EITHER ONE WHEN ORDERING	When steel ball indenter is selected : 10 / When Carbide ball indenter is selected : 2
R-021	ANVIL	FLAT (φ 60mm) 1
R-022	ANVIL	V-SHAPE (LARGE) 1
R-042	POWER CABLE(3P-2.5m)	1
R-043	LEVEL ADJUSTING LEG	4
R-044	MACHINE COVER	1
—	INSTRUCTION AND MAINTENANCE MANUAL	1
—	HARDNESS CONVERSION CHART	1
R-045	ACCESSORY BOX	1



OPTIONAL ACCESSORIES



R-050
EXCEL DATA TRANSFER
SOFTWARE ATTACHED
WITH RS232C CABLE



R-001
DIGITAL PRINTER

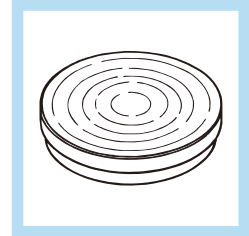

R-028
ROUND TABLE ϕ 200mm

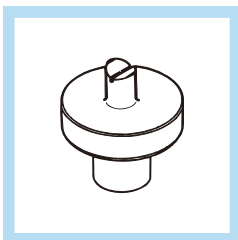

R-023
ANVIL V-SHAPE (Small)

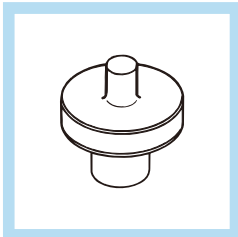

R-025
ANVIL SPOT
(Flat tip ϕ about 8.5 mm)

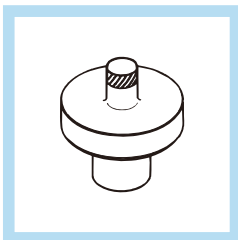

R-026
ANVIL CARBIDE SPOT

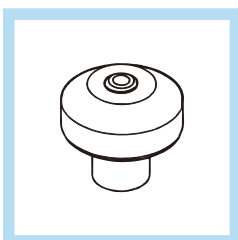

R-027
ANVIL DIAMOND SPOT

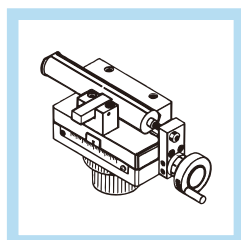

R-029
MICRO TEST TABLE
FOR JOMINY TEST

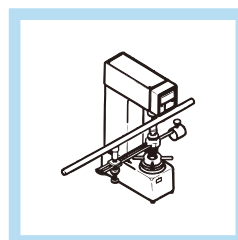

R-030
LONG SPECIMEN
TESTING JIG VARI-REST

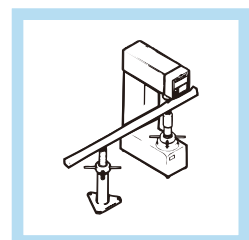

R-031
LONG SPECIMEN
TESTING JIG JACK-REST

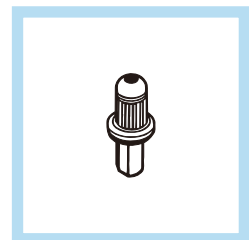

R-005
STEEL BALL INDENTER
 ϕ 1/8"

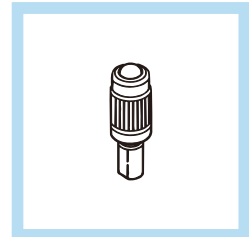

R-006
STEEL BALL INDENTER
 ϕ 1/4"

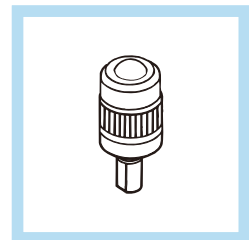

R-007
STEEL BALL INDENTER
 ϕ 1/2"

ROCKWELL HARDNESS SCALE AND ITS INFORMATION

SCALE	HARDNESS	INDENTER	PRE FORCE F ₀ (N)	TEST FORCE F (N)	CONSTANT S (mm)	EACH SCALE CONSTANT N	FIELD OF APPLICATION
A	HRA	DIAMOND CONE	98.07	588.4	0.002	100	20 ~ 95 HRA
B	HRB	BALL 1/16 inch	98.07	980.7	0.002	130	10 ~ 100 HRB
C	HRC	DIAMOND CONE	98.07	1 471	0.002	100	20 ^{a)} ~ 70 HRC
D	HRD	DIAMOND CONE	98.07	980.7	0.002	100	40 ~ 77 HRD
E	HRE	BALL 1/8 inch	98.07	980.7	0.002	130	70 ~ 100 HRE
F	HRF	BALL 1/16 inch	98.07	588.4	0.002	130	60 ~ 100 HRF
G	HRG	BALL 1/16 inch	98.07	1 471	0.002	130	30 ~ 94 HRG
H	HRH	BALL 1/8 inch	98.07	588.4	0.002	130	80 ~ 100 HRH
K	HRK	BALL 1/8 inch	98.07	1 471	0.002	130	40 ~ 100 HRK

Note) The field of application can be extended to 10 HRC if the indenter possesses the appropriate dimensions.

ROCKWELL SUPERFICIAL SCALE AND ITS INFORMATION

SCALE	HARDNESS	INDENTER	PRE FORCE F ₀ (N)	TEST FORCE F (N)	CONSTANT S (mm)	EACH SCALE CONSTANT N	FIELD OF APPLICATION
15N	HR15N	DIAMOND CONE	29.42	147.1	0.001	100	70 ~ 95 HR15N
30N	HR30N	DIAMOND CONE	29.42	294.2	0.001	100	42 ~ 86 HR30N
45N	HR45N	DIAMOND CONE	29.42	441.3	0.001	100	20 ~ 77 HR45N
15T	HR15T	BALL 1/16 inch	29.42	147.1	0.001	100	67 ~ 93 HR15T
30T	HR30T	BALL 1/16 inch	29.42	294.2	0.001	100	29 ~ 82 HR30T
45T	HR45T	BALL 1/16 inch	29.42	441.3	0.001	100	10 ~ 72 HR45T

※ Appearance and specifications are subject to change without prior notice for the product improvement.



FUTURE-TECH CORP.

<http://www.ft-hardness.com>

HEAD OFFICE

TALKPIER KAWASAKI BLDG., NO. 5-1, 3-CHOME, FUJISAKI,
KAWASAKI-KU, KAWASAKI, KANAGAWA, 210-0804 JAPAN
TEL. +81-44-270-5789 TEL. +81-44-266-6779
E-mail: info@ft-hardness.com

EUROPEAN REPRESENTATIVE OFFICE:

VIA MATTEOTTI 23/E, 20090 ASSAGO(MILAN),ITALY
TEL/FAX: +39-02-91669470 MOBILE. +39-335-1803592
E-mail: cantoni.fte@gmail.com

FUTURE-TECH (ASIA) CO., LTD. :

777/11 MOO 9, BANGPLA, BANGPLEE,
SAMUTPRAKARN 10540, THAILAND
TEL: +66-2-136-6281 FAX. +66-6-136-6282
E-mail: siripong@ft-hardness.com



We are based on JIS Q 17025 (ISO/IEC 17025) as accredited standards, and accredited by JCSS who manages the recognition scheme according to ISO/IEC 17011. IA Japan (accreditation organization who has managed JCSS) who is signatory to the Mutual Recognition Arrangement (MRA) of International Laboratory Accreditation Cooperation (ILAC) and Asia Pacific Accreditation Cooperation (APAC). We are accredited as MRA Calibration Laboratory of JCSS. Our accreditation number is JCSS 0228.

